

a1	b1	c1	e1	f1	s1	h1	p2	m	l	d	t	u	M
160	110	10	130	3,5	9	98	178	135	40	20	22,5	6	M6

	63 S-L	71 S-L	80 S-L	90 S	90 L
k	349	365	382	399	424
k1	405	485	502	524	549

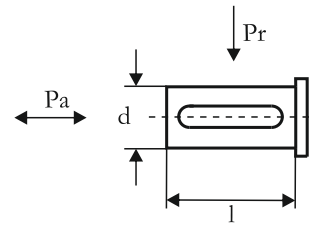

Klemens Kutusu Bağlantı Pozisyonları
Mounting position of terminal box

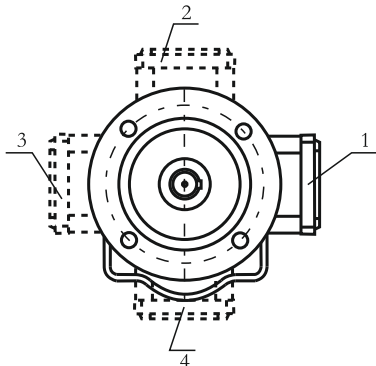

$T_2 \text{ max(Nm)} : 100$

Yük
Load

Çıkış Devir Sayısı n_2
Output speed n_2

	0-15	30-50	15-30	50-100	100-140
P_r (N)	1300	1200	1000	900	800
P_a (N)	500	450	400	350	300

Redüktöre gelen radyal ve eksenel yükler
Radial and axial loads on the gearbox

MİL ÇAP TOLERANSLARI
0-50 mm ISO K6
50mm üstü ISO J6
k1 Frenli redüktörlere aittir.

Shaft diameter tolerances
0-50 mm ISO K6
Up 50 mm ISO J6
Dimensions k1 is for motors with brake