

a1	b1	c1	e1	f1	s1	h1	p2	m	l	d	t	u	M
200	130	12	165	3,5	11	153	253	170	70	35	38	10	M10

	63 SL	71 SL	80 SL	90 S	90 L
k	460	479	496	513	538
k1	516	599	616	638	663

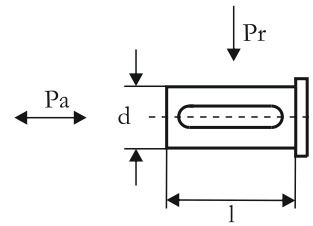

Klemens Kutusu Bağlantı Pozisyonları  
Mounting position of terminal box

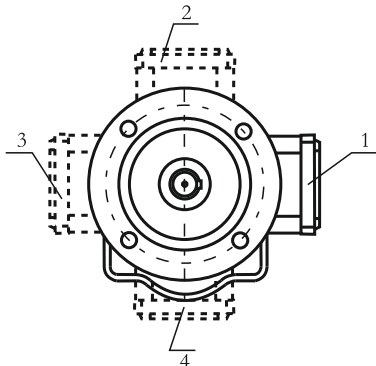

$T_2 \text{ max(Nm)} : 400$

Yük  
Load

Çıkış Devir Sayısı  $n_2$   
Output speed  $n_2$

	0-15	30-50	15-30	50-100	100-140
$P_r$ (N)	3800	3300	3000	2600	2400
$P_a$ (N)	1500	1350	1150	950	850

Redüktöre gelen radyal ve eksenel yükler  
Radial and axial loads on the gearbox

MİL ÇAP TOLERANSLARI  
0-50 mm ISO K6  
50mm üstü ISO J6  
k1 Frenli redüktörlere aittir.

Shaft diameter tolerances  
0-50 mm ISO K6  
Up 50 mm ISO J6  
Dimensions k1 is for motors with brake