

a1	b1	c1	e1	f1	s1	h1	p2	m	l	d	t	u	M
160	110	12	130	3,5	9	123	203	150	50	25	28	8	M8

	63 SL	71 S-L	80 S-L
k	334	453	468
k1	446	573	588

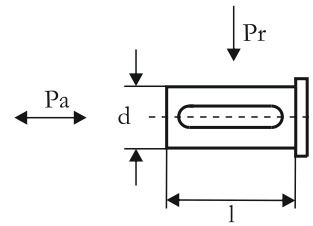

Klemens Kutusu Bağlantı Pozisyonları
Mounting position of terminal box

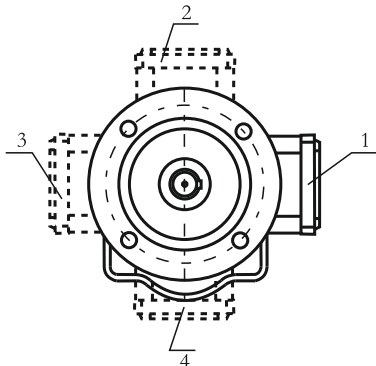

$T_2 \text{ max(Nm)} : 200$

Yük
Load

Çıkış Devir Sayısı n_2
Output speed n_2

	0-15	30-50	15-30	50-100	100-140
P_r (N)	2100	1900	1700	1500	1300
P_a (N)	850	750	700	650	600

Redüktöre gelen radyal ve eksenel yükler
Radial and axial loads on the gearbox

MİL ÇAP TOLERANSLARI
0-50 mm ISO K6
50mm üstü ISO J6
k1 Frenli redüktörlere aittir.

Shaft diameter tolerances
0-50 mm ISO K6
Up 50 mm ISO J6
Dimensions k1 is for motors with brake