

a	b	c	e	f	s	i	h	p	m	l	d	t	u	M
85	105	15	110	135	8,5	68	102	170	135	40	20	22,5	6	M6

	63 SL	71 S-L	80 S-L	90 S	90 L
k	349	365	382	399	424
k1	405	485	502	524	549

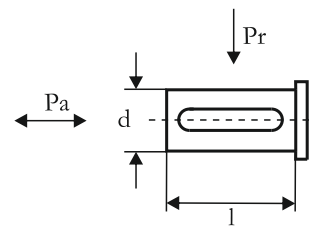

Klemens Kutusu Bağlantı Pozisyonları  
Mounting position of terminal box

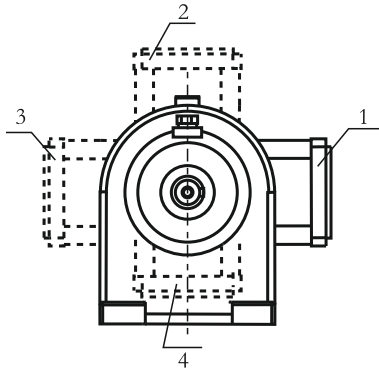

$T_2 \max(\text{Nm}) : 100$

Yük  
Load

Çıkış Devir Sayısı  $n_2$   
Output speed  $n_2$

	0-15	30-50	15-30	50-100	100-140
$P_r$ (N)	1300	1200	1000	900	800
$P_a$ (N)	500	450	400	350	300

Redüktöre gelen radyal ve eksenel yükler  
Radial and axial loads on the gearbox

MİL ÇAP TOLERANSLARI  
0-50 mm ISO K6  
50mm üstü ISO J6  
k1 Frenli redüktörlere aittir.

Shaft diameter tolerances  
0-50 mm ISO K6  
Up 50 mm ISO J6  
Dimensions k1 is for motors with brake