

a	b	c	e	f	s	i	h	p	m	l	d	t	u	M
85	185	20	125	210	13	86	155	240	170	70	35	38	10	M10

	63 SL	71 SL	80 SL	90 S	90 L
k	460	479	496	513	538
k1	516	599	616	638	663

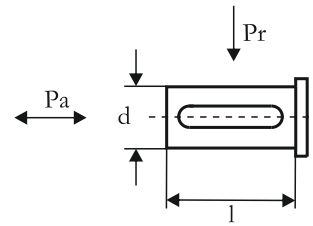

Klemens Kutusu Bağlantı Pozisyonları
Mounting position of terminal box

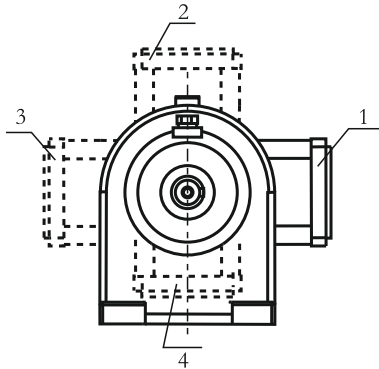

$T_2 \max(\text{Nm}) : 400$

Yük
Load

Çıkış Devir Sayısı n_2
Output speed n_2

	0-15	30-50	15-30	50-100	100-140
Pr (N)	3800	3300	3000	2600	2400
Pa (N)	1500	1350	1150	950	850

Redüktöre gelen radyal ve eksenel yükler
Radial and axial loads on the gearbox

MİL ÇAP TOLERANSLARI
0-50 mm ISO K6
50mm üstü ISO J6
k1 Frenli redüktörlere aittir.

Shaft diameter tolerances
0-50 mm ISO K6
Up 50 mm ISO J6
Dimensions k1 is for motors with brake