

a	b	c	e	f	s	i	h	p	m	l	d	t	u	M
190	260	35	230	314	18	134	250	375	250	100	50	53,5	16	M14

	100 S	112 M	132 S	160 M	160 L
k	616	630	715	784	828
k1	751	765	860	954	998

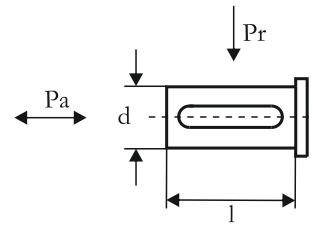

Klemens Kutusu Bağlantı Pozisyonları
Mounting position of terminal box

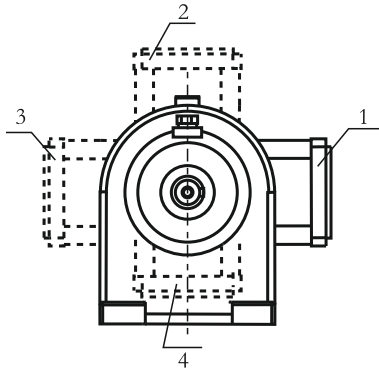

$T_2 \text{ max(Nm)} : 1200$

Yük
Load

Çıkış Devir Sayısı n_2
Output speed n_2

	0-15	30-50	15-30	50-100	100-140
P_r (N)	5200	4500	3900	3500	3000
P_a (N)	2100	1900	1700	1500	1200

Redüktöre gelen radyal ve eksenel yükler
Radial and axial loads on the gearbox

MİL ÇAP TOLERANSLARI
0-50 mm ISO K6
50mm üstü ISO J6
k1 Frenli redüktörlere aittir.

Shaft diameter tolerances
0-50 mm ISO K6
Up 50 mm ISO J6
Dimensions k1 is for motors with brake