

a1	b1	c1	e1	f1	s1	h1	p2	m	l	d	t	u	M
200	130	14	165	3,5	11	173	273	200	80	40	43	14	M12

	71 SL	80 SL	90 S	90 SL	100 L
k	520	537	554	579	612
k1	640	657	679	704	747

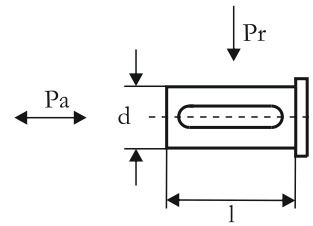

Klemens Kutusu Bağlantı Pozisyonları  
Mounting position of terminal box

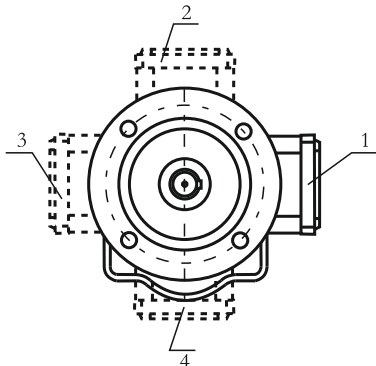

$T_2 \max(\text{Nm}) : 700$

Yük  
Load

Çıkış Devir Sayısı  $n_2$   
Output speed  $n_2$

	0-15	30-50	15-30	50-100	100-140
$P_r$ (N)	4200	3800	3400	3000	2400
$P_a$ (N)	1700	1500	1300	1100	900

Redüktöre gelen radyal ve eksenel yükler  
Radial and axial loads on the gearbox

MİL ÇAP TOLERANSLARI  
0-50 mm ISO K6  
50mm üstü ISO J6  
k1 Frenli redüktörlere aittir.

Shaft diameter tolerances  
0-50 mm ISO K6  
Up 50 mm ISO J6  
Dimensions k1 is for motors with brake