

a1	b1	c1	e1	f1	s1	h1	p2	m	l	d	t	u	M
200	130	12	165	3,5	11	153	253	170	70	35	38	10	M10

	80 SL	90 S	90 L	100 L	112 M
k	452	469	494	527	541
k1	572	594	619	662	676

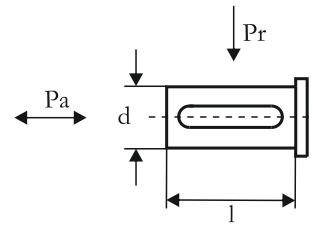

Klemens Kutusu Bağlantı Pozisyonları
Mounting position of terminal box

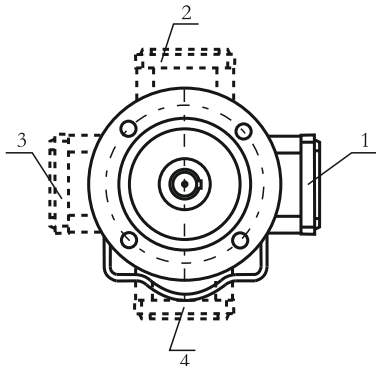

$T_2 \max(\text{Nm}) : 400$

Yük
Load

Çıkış Devir Sayısı n_2
Output speed n_2

	0-15	30-50	15-30	50-100	100-140
Pr (N)	3800	3300	3000	2600	2400
Pa(N)	1500	1350	1150	950	850

Redüktöre gelen radyal ve eksenel yükler
Radial and axial loads on the gearbox

MİL ÇAP TOLERANSLARI
0-50 mm ISO K6
50mm üstü ISO J6
k1 Frenli redüktörlere aittir.

Shaft diameter tolerances
0-50 mm ISO K6
Up 50 mm ISO J6
Dimensions k1 is for motors with brake