

a	b	c	e	f	s	i	h	p	m	l	d	t	u	M
134	175	25	165	215	13	120	175	275	200	80	40	43	14	M12

	71 SL	80 SL	90 S	90 SL	100 L
k	520	537	554	579	612
k1	640	657	679	704	747

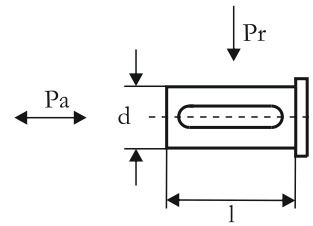

Klemens Kutusu Bağlantı Pozisyonları
Mounting position of terminal box

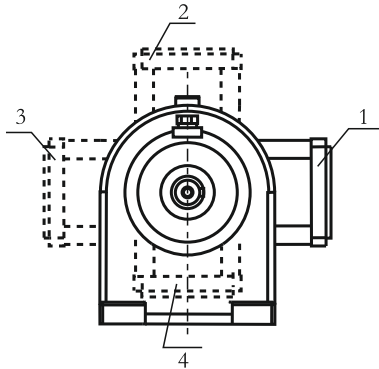

$T_2 \text{ max(Nm)} : 700$

Yük
Load

Çıkış Devir Sayısı n_2
Output speed n_2

	0-15	30-50	15-30	50-100	100-140
P_r (N)	4200	3800	3400	3000	2400
P_a (N)	1700	1500	1300	1100	900

Redüktöre gelen radyal ve eksenel yükler
Radial and axial loads on the gearbox

MİL ÇAP TOLERANSLARI
0-50 mm ISO K6
50mm üstü ISO J6
k1 Frenli redüktörlere aittir.

Shaft diameter tolerances
0-50 mm ISO K6
Up 50 mm ISO J6
Dimensions k1 is for motors with brake